

E-Archive is designed to **keep electronic documents legal** even after a long term document storage. Together with its document services, the system can guarantee legal validity of stored documents, security and limited access to document nodes, document types and documents.

The system is able to store millions of documents, manages document export, allows metadata updating and through appropriate scaling, is able to receive unlimited number of documents in seconds. Documents of any format and type can be archived through a programmatic interface which is exposed as an Inbound Document Sink.

The solution is targeted to **service providers** and **large organizations**, which want to implement document archive services by themselves. There is support to implement multiple large document archives within the same installation. Every archive has full autonomy, and presents complete functionality to outside users.

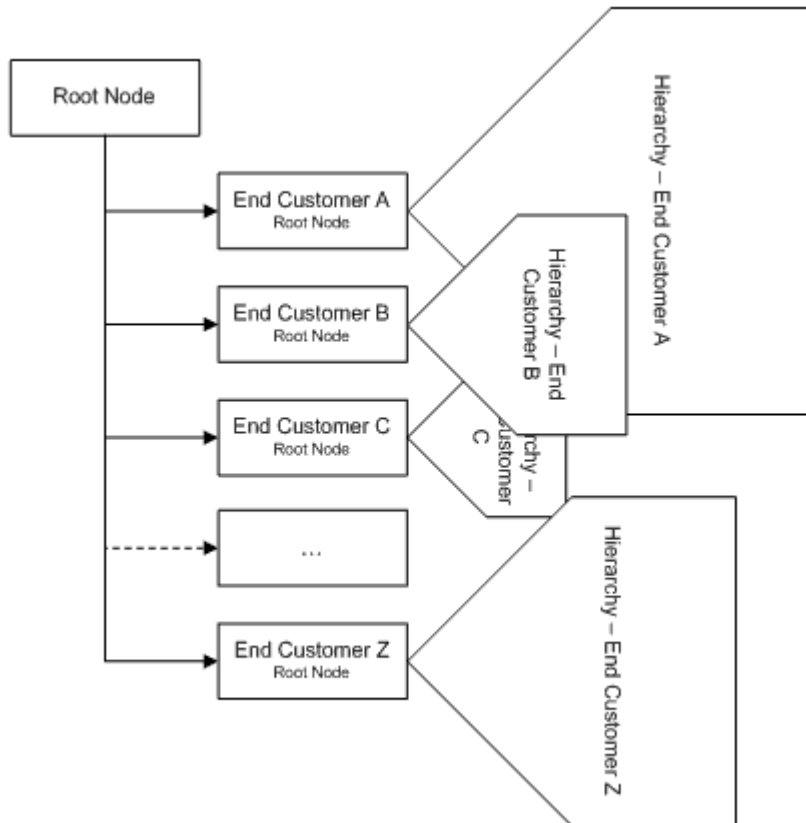

All entry points (named Inbound Document Sinks) transfer documents to Main Document Sink, via Middle Document Sink and provide abstraction of document processing.

Logical hierarchy can be defined arbitrarily and is limited to administrative rights of the end customer. The following picture represents a simple archive hierarchy:

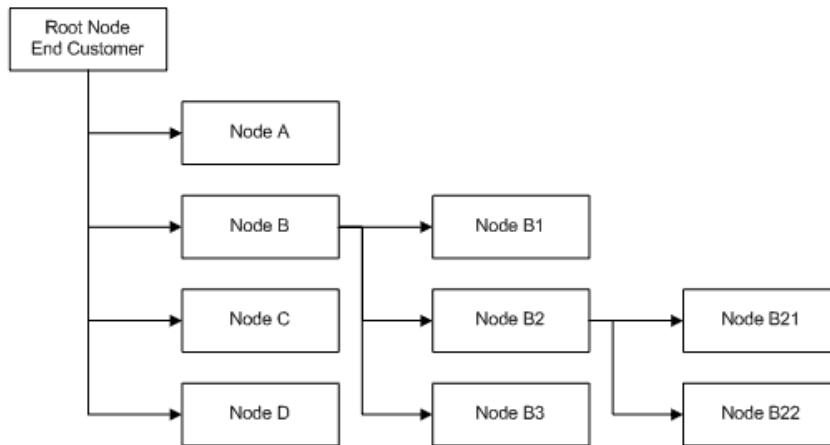

Main system functionalities are:

- Modular system, designed using **Microsoft .NET Framework 3.0** platform
- Support for electronic documents
- Archive search
- Administrative module
- Settable parameters via entry rules
- Arbitrary document format support (Microsoft Office, Adobe PDF, XML, ...)
- Support for digital signature, time stamping and / or encryption

E-Archive solution is document based. Interaction with the archive is done using XML documents, results are returned as signed and well formed XML documents. Dynamic XML Schemas are returned via the same service as other functionalities.

Basic architecture is designed around three document sink types:

- Inbound Document Sink
- Middle Document Sink
- Middle Document Sink

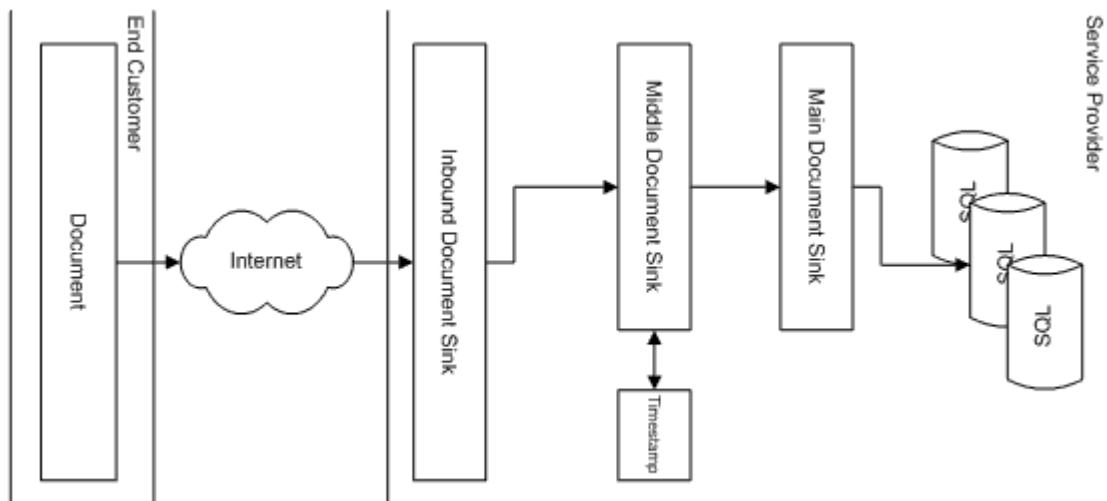

Document sinks combine into a document pipeline, which defines a physical server path through the system. Documents are stored on a permanent medium after they leave Main Document Sink. Application services then provide legal value to stored documents.

Document lifetime can be composed of complex activities. The following case defines a typical document lifetime:

- **Document Arrival**

Document is received by one of the Inbound Document Sinks. Sinks are implemented for different storage scenarios and allow different ways of entering the document archive.

- **Processing and Transfer of Document**

All documents are transferred into Middle Document Sink, where they are processed and sent into Main Document Sink. Processing of documents is controlled using the internal setting of the system. Entry rules are applied on every stage and document is sent into the permanent storage.

- **Document Use**

Documents can be used normally, retrieved and reclassified. Every action is logged and time stamped.

- **Moving of Document**

Document can be moved from fast onto a slow medium, depending on metadata and entry rules. In cases when document is only stored on slow medium, it is transferred back on-demand and made available to end customers.

- **Re-timestamping**

The system allows dynamic re-timestamping of documents, based on metadata and entry rules. Old timestamps are retained and form a timestamp chain, which can be validated.

- **Deletion of Document**

Document can be deleted but its metadata and physical representation is retained.

- **Destroying Documents**

Permanent destruction of documents is possible with a joint approval of two archive administrators. Even though physical representation cannot be retrieved after document is destroyed, metadata is still available.

E-Archive Solution is designed for large organizations, which demand legal validation of electronic documents and their preservation. The system has support for integration with our document system eDocs, which can be used as one of the entry points in the archiving process.